

INTEGRATED OPTIMAL POWER FLOW FOR ELECTRIC POWER AND HEAT IN A MICROGRID

Bieshoy AWAD Modassar CHAUDRY Jianzhong WU Nick JENKINS
 Cardiff University – UK University of Manchester – UK Cardiff University – UK Cardiff University – UK
 awadba@cardiff.ac.uk modassar.chaudry@manchester.ac.uk wuj5@cardiff.ac.uk jenkinsn6@cardiff.ac.uk

ABSTRACT

Optimal power flow (OPF) programs are employed for optimising the operation of electric power networks whilst satisfying all network constraints. Their formulation is based on electric power flow equations and power system constraints, while other energy systems, such as gas and heat, are insufficiently represented.

A formulation of an integrated OPF for power, and heat networks in a MicroGrid is described. Flow equations representing electric power, hot water, and heat systems are considered. The model is demonstrated on a simple network with different operational constraints.

NOMENCLATURE

Symbols

c_p : Specific heat of water at constant pressure
 d_1, d_2 : Constants
 F : Coefficient relating pressure drop to flow rate
 L : Pipe length
 M : A set of heat and power sources in the MicroGrid
 \dot{m} : Mass flow rate
 P : Power
 p : Pressure
 Q : Reactive power
 S : Set of all elements supplying water to a certain node
 T : Temperature
 t : Transformer tap position
 $V=e+jf$: Voltage
 $Y=G-jB$: An element of the bus admittance matrix
 λ : Heat transfer coefficient of a pipe per unit length
 η : Efficiency

Subscripts

MS : MicroSource
 CHP : Combined heat and power
 $Pump$: Pump
 IH : Immersion heater
 T : Total, (Including both heat and power)
 P : Electric power
 H : Heat
 F : Fuel
 in : input / inlet
 out : output / outlet
 a : ambient
 S : Supply line
 R : Return line
 n : Node

INTRODUCTION

The Recent targets agreed by the EU and adopted by the UK government's energy policy that leads to a sustainable low carbon energy system, encourages the increase in renewable energy, demand reduction through improved energy efficiency, and carbon emissions reduction, the bulk of which will be met by the power industry [1]. This will result in a greater dependence on renewable generation, micro-generation, combined heat and power (CHP) units, and biomass. Hence, more MicroGrids, defined in [2] as small energy networks that supply the local area with heat and electric power, are expected to be built.

Heat production in a MicroGrid is either local, at consumer sites, or centralised. In the case of centralised heat production, a district heat network is necessary to distribute the produced heat among consumers. While local heat production uses natural gas, district heating can use cruder fuels such as biomass [3, 4]. Additionally, operational cost optimisation has shown to favour the use of a single μ CHP unit to supply multiple consumers rather than using individual units for each consumer [5]

Generating units in MicroGrids, MicroSources, are driven either by the available renewable energy or by local heat demand. This reduces the control margin of their active power generation. Hence, energy storage equipment is employed to compensate for less flexible power generation.

Different forms of energy storage are available. Electrical energy can be stored in flywheels and battery banks. Lower cost options include, heat storage in hot water tanks and fuel storage in gas reservoirs. The operational flexibility of heat and gas systems allow energy to be stored in building mass [6], space temperature, water pipes, and gas line pack[7]. The choice of energy storage form depends on capital/operational costs, the ability to restore this energy and capability of transforming it into another form if required.

The district heat network, the gas network, and the power network in a MicroGrid are interconnected together through equipment such as: boilers, CHP units, micro-turbines, fuel cells, immersion heaters, water pumps, and gas compressors. This variety of connection points facilitates the conversion of one form of energy to another in order to optimise system operation and usage of storage facilities.

The three energy networks, heat, gas, and power, are currently analysed, optimised, and operated independently. Since the interdependence between them is increasing, an integrated approach to their operation is required.

Integrated energy networks have been studied in [7-9]. In [8, 9] the concept of energy hubs was established in order to provide a formal approach to deal with integrated energy networks. Optimisation problems such as economic dispatch and optimal power flow were introduced for the integrated energy network [8]. In [7], an OPF was used for operational optimisation of the integrated gas and electricity network of Great Britain. Most of these studies concentrated on integrating gas and power networks. Heat networks are not fully modelled in any of the integrated energy optimisation models.

The formulation of an integrated OPF for heat and power networks was investigated. The OPF includes modelling the physical components of both district heat and electric power systems. A MicroGrid was used as a case study for the integrated OPF. Different scenarios were considered in order to assess the importance of an integrated approach to energy network optimisation.

MODELLING OF THE INTEGRATED ENERGY SYSTEM

The heat and power networks were modelled individually but interconnected together via the district heat station.

Electric Power Network

The power network is represented by the power balance equations [10] at all busbars. These equations are expressed for busbar i by equation (1) where N is the total number of busbars, and P_i and Q_i are the total active and reactive power injection at busbar i .

$$P_i = \sum_{q=1}^N (e_i (e_j G_{ij} + f_j B_{ij}) + f_i (f_j G_{ij} - e_j B_{ij})) \quad (1)$$

$$Q_i = \sum_{j=1}^N (f_i (e_j G_{ij} + f_j B_{ij}) - e_i (f_j G_{ij} - e_j B_{ij}))$$

Active and reactive power generation limits for the MS MicroSource are given by equation (2) where P_{MS-Max} is the maximum power generation limit due to available power at the prime mover and $P_{MS-Rated}$ is the MicroSource rating. No upper limit was imposed on the grid connection as it is assumed to be an infinite system.

$$P_{MS-Min} \leq P_{MS} \leq P_{MS-Max} \quad (2)$$

$$Q_{MS-Min} \leq Q_{MS} \leq Q_{MS-Max}$$

Transmission lines were assumed to allow bi-directional power transfer up to their thermal limit.

$$-P_{Line-Max} \leq P_{Line} \leq P_{Line-Max} \quad (3)$$

Continuous tap changer operation was assumed between the minimum and maximum tap positions of the transformer.

$$t_{Min} \leq t \leq t_{Max} \quad (4)$$

A $\pm 6\%$ voltage limit constraint was imposed on all busbar voltage magnitudes.

$$0.94 \leq \sqrt{e_p^2 + f_p^2} \leq 1.06 \quad (5)$$

District Heat Network

The district heat network model is based on the models used in the electricity and pipe network analysis software SIEMENS PSS SINCAL [11] and those investigated in [12, 13]. Some approximations were made in order to simplify the optimisation process. The elements represented in the model are heat sources, heat loads, district hot water pipes, and pumps at the heat substation.

Heat sources and consumer heat exchangers are the points at which heat energy is injected into or extracted from the network. The power exchange is determined by water mass flow rate and temperature difference between the supply and return lines as shown in equation (6).

$$P = c_p \dot{m} (T_S - T_R) \quad (6)$$

The temperature drops exponentially during water flow in pipes [11]. The water temperature at the outlet of a pipe is calculated by equation (7).

$$T_{out} = (T_{in} - T_a) e^{-\frac{\lambda L}{c_p \dot{m}}} + T_a \quad (7)$$

This relation is approximated into equation (8)

$$T_{out} = \begin{cases} (T_{in} - T_a) \left(1 - \frac{\lambda L}{c_p \dot{m}} \right) + T_a & \frac{\lambda L}{c_p \dot{m}} \leq 1 \\ T_a & \frac{\lambda L}{c_p \dot{m}} > 1 \end{cases} \quad (8)$$

The water temperature at the pipe inlet, T_i , is equal to the water temperature at the node to which the pipe inlet is connected, T_n . This value is calculated from equation (9).

$$T_n = \frac{\sum_{j \in S} \dot{m}_j T_{oj}}{\sum_{j \in S} \dot{m}_j} \quad (9)$$

The static pressure drop along a pipe is directly proportional to the square of the mass flow rate [13]. This is in full agreement with [11] at highly turbulent flow and constant water density. The pressure drop is given by equation (10) where F is constant.

$$p_i - p_o = F \dot{m}^2 \quad (10)$$

One district heat station provides the reference pressure values for both the supply and return lines. Pressure values at other heat stations and consumers are calculated as functions of the reference values and flow rates. There is no direct relationship between the pressure difference between the supply and return lines at a heat station or a consumer and their mass flow rates. The supply and return networks are thus modelled as two independent networks coupled only through flow rates [11, 12].

District Heat Stations

District heat stations are points of coupling between heat and electricity networks. They are assumed to contain a

CHP unit, an immersion heater, and a water pump. Figure 1 is a schematic diagram showing energy conversion processes taking place in a district heat station. Relations governing these processes are listed in equation (11).

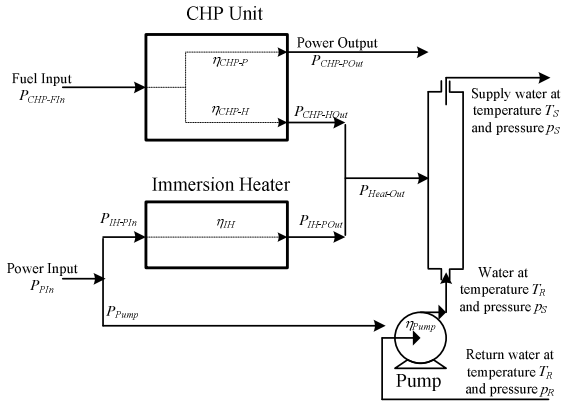

Figure 1: Schematic Diagram of a District Heat Station

$$P_{Heat-out} = P_{CHP-Fin} \eta_{CHP-H} + P_{IH-Pin} \eta_{IH} \quad (11)$$

$$P_{Elec-out} = P_{CHP-Fin} \eta_{CHP-P}$$

The power required by the pump is related to the mass flow rate and the static pressure difference by equation (12)

$$P_{Pump} = \frac{\dot{m}(p_S - p_R)}{\rho \eta_{Pump}} \quad (12)$$

The CHP electric power efficiency decreases linearly with the increase in hot water supply temperature as shown by equation (13) [12]. This is also accompanied by an increase in the heat efficiency such that the combined efficiency of the CHP unit remains constant as shown in equation (14).

$$\eta_{CHP-P} = d_1 - d_2 T_s \quad (13)$$

$$\eta_{CHP-T} = \eta_{CHP-P} + \eta_{CHP-H} \quad (14)$$

Objective Function

The objective is to minimise total operating costs whilst satisfying total heat and power load. Linear relations were used to represent the cost associated with MicroSources, grid connection, and CHP units. The total cost is given by equation (15).

$$f = \sum_{i \in M} c_i P_i \quad (15)$$

CASE STUDY

The integrated OPF was used to optimise the operation of the MicroGrid heat and power network shown in Figure 2. Details of the power network is given in [14]. Heat network data is given in Table 1. The CHP, immersion heater, and pump are connected at busbar Bus12 (data is given in Table 2).

Retail prices of 10.69p/kWh for electrical energy from the grid and 2.69p/kWh for CHP fuel were used for the cost

functions [15]. Zero energy prices were used for the MicroSources and a high energy price of 20.0p/kWh was used for the flywheel. Reverse power flow was not allowed and a fully charged flywheel was assumed.

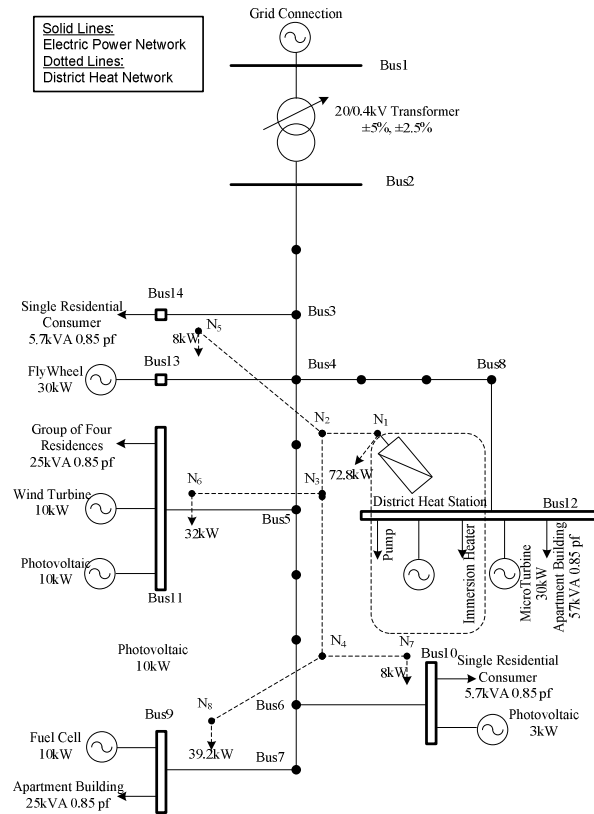

Figure 2: MicroGrid Heat and Power Network

Table 1: Data for District Heat Network Pipes

From	To	L (m)	F (m ² /kg)	λ (W/m ² K)
N1	N2	140	0.094856	0.25×10 ⁻³
N2	N3	70	0.047428	0.25×10 ⁻³
N3	N4	70	0.047428	0.25×10 ⁻³
N2	N5	70	0.18104	0.35×10 ⁻³
N3	N6	30	0.077588	0.35×10 ⁻³
N4	N7	70	0.18104	0.35×10 ⁻³
N4	N8	30	0.077588	0.35×10 ⁻³

Table 2: District Heat Station Data

η _{IH}	η _{CHP-C}	D ₁	d ₂
0.9	0.9	0.1875	0.00125

Table 3: Case Study Scenarios

Scenario	Heat Loads	Electric Loads	Available MicroSource Generation
1	Full Load	No Load	None available
2	Full Load	Full Load	None available
3	Full Load	No Load	Rated power available
4	Full Load	Full Load	Rated power available

Table 4: Integrated OPF Results

Scenario	1	2	3	4
Source supply temperature (°C)	100	80.67	100	80.8
District heat source power output	173.5	171.0	173.5	171.0
CHP Gas input (kW)	207.1	210.2	148.6	210.2
Immersion heater power (kW)	0.08	0	58.64	0
CHP power output (kW)	12.94	18.22	9.28	18.18
Pump power (kW)	12.86	16.71	12.87	16.68
Total MicroSource generation (kW)	0	0	63.0	63.0
Grid power (kW)	0	103.4	0	36.8
Total domestic load (kW)	0	100.6	0	100.6
Operating cost (£/h)	2.7	13.2	1.5	6.0

Four scenarios, listed in Table 3, were considered for assessing the integrated heat and power OPF. The OPF results are listed in Table 4.

The district heat station supply temperature exhibits high values at low load conditions and low values at high load conditions. This varies the CHP efficiency in order to increase its heat output at low load conditions or to increase its electrical power output at high load conditions.

The immersion heater was only used at high local power generation. This reduces CHP fuel consumption when cheap electrical power is available.

CONCLUSION

An integrated heat and optimal power flow was investigated. Interconnections between heat and power networks were modelled. The OPF results were compared for four different scenarios.

The integrated OPF varies the heat network settings to reflect changes in the power network, such that the operation of the CHP, immersion heater, and pump reduces the difference between electric power production and demand. This minimises system operating costs and saves fuel stocks to be used when cheap electric power is not available.

ACKNOWLEDGMENT

The first author wishes to acknowledge his sponsors, The Egyptian Government and the Egyptian Cultural Bureau in London for their support.

REFERENCES

[1] European Parliament, 2008, "European parliament

seals climate package", *EU Press Release*, [cited January 2009]; Available from: http://www.europarl.europa.eu/pdfs/news/expert/infopress/20081216IPR44857/20081216IPR44857_en.pdf.

- [2] N. Hatziaargyriou, N. Jenkins, *et al.*, 2006, "Microgrids-large scale integration of microgeneration to low voltage grids". *CIGRE session*, CIGRE.
- [3] R. McDougall and B. Jensen, 2008, "District heating systems for small scale development areas", *The 11th International Symposium on District Heating and Cooling*.
- [4] European Commission, "Biomass plant and district heating system rehabilitation project in Lithuania". [cited January 2009], Available from: http://www.energie-cites.org/db/ignalina_140_en.pdf.
- [5] M. Chaudry, J. Ekanayake, and N. Jenkins, 2008, "Optimum control strategy for a μ CHP unit", *International Journal of Distributed Energy Resources*. vol. 4(4), 265-280.
- [6] L.C.O. Ingvarson and S. Werner, 2008, "Building mass used as short term heat storage", *The 11th International Symposium on District Heating and Cooling*.
- [7] M. Chaudry, N. Jenkins, and G. Strbac, 2008, "Multi-time period combined gas and electricity network optimisation", *Electric power systems Research*. vol. 78(7), 1265-1279.
- [8] M. Geidl, 2007, *Integrated Modeling and Optimization of Multi-Carrier Energy Systems*, PhD thesis, Power Systems Laboratory, ETH Zurich.
- [9] M. Geidl and G. Andersson, 2005, "Operational and topological optimization of multi-carrier energy systems", *International Conference on Future Power Systems*, IEEE.
- [10] G. W. Stagg and A. H. El-Abiad, 1968, *Computer Methods in Power System Analysis*, McGraw-Hill, New York.
- [11] PSSTM SINCAL Heating Manual, 2007, "Heating calculations in flow networks", V5.4, SIEMENS AG.
- [12] H. Zhao, 1995, *Analysis, Modelling and Operational Optimization of District Heating Systems*, PhD thesis, Centre for District Heating Technology, Technical University of Denmark.
- [13] V. D. Stevanovic, S. Prica, *et al.*, 2007, "Efficient numerical method for district heating system hydraulics", *Energy Conversion and Management*. vol. 48, 8.
- [14] S. Papathanassiou, N. Hatziaargyriou, and K. Strunz, 2005, "A benchmark low voltage microgrid network", *Proceedings of the CIGRE Symposium: Power Systems with Dispersed Generation*.
- [15] British Gas, "Websaver gas and electricity domestic prices for January 2009", [cited 2009 January]; Available from: <http://www.britishgas.co.uk>.